

EXPLOSION-PROOF CONNECTION HEAD WITH WELDED PROCESS CONNECTION

How to build a part number:

To order an Applied Sensor Technologies temperature sensor, select the requirements for the categories listed below and fill in the corresponding boxes with your selection. Don't see exactly what you need? Give us a call!

SENSOR TYPE	ASSEMBLY STYLE	SHEATH DIAMETER	SHEATH MATERIAL	TEMPERATURE RANGE	SHEATH LENGTH	OPTIONS

SENSOR TYPE (See page 2-3b for optional elements)

RTP1 – Platinum; DIN 0.00385; 100 ohm +/- 0.12% @ 0°C; 3-wire construction

(For dual element, add prefix "D" - e.g., DRTP1)

ASSEMBLY STYLE

78 – Sheath with cast aluminum head and 1/2" NPT welded stainless steel process connection; head CSA/FM approved for Class I, Division I, Groups B, C, D; Class II, Groups E, F, G; screw cover with chain and gasketed o-ring; meets NEMA 4; ceramic terminal block; 1/2" NPT conduit connection

SHEATH DIAMETER (in inches) (see below for restrictions)

4 – 1/8 (0.125)

6 – 3/16 (0.188)

7 – 1/4 (0.250)

9 – 3/8 (0.375)

SHEATH MATERIAL

3 – 316 stainless steel

TEMPERATURE RANGE - Minimum and maximum operating temperatures

1 – -45 to 260°C (-50 to 500°F)

2 – -45 to 482°C (-50 to 900°F)

3 – -45 to 788°C (-50 to 1450°F)

4 – -200 to 260°C (-328 to 500°F)

SHEATH LENGTH (for lengths greater than L=36", consult AST)

L# – (e.g., L6 = 6 inch sheath)

OPTIONS – see back page

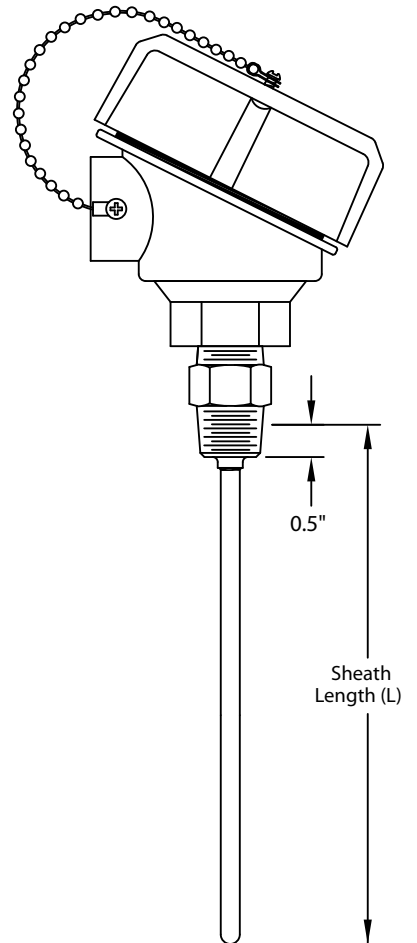

Smallest Diameter Sheath Available By Sensor Type and Temperature Range							
SINGLE							
Temp Range	RTP 1	RTP 1A	RTP 1AA	RTP 6	RTP 7	RTP 7A	RTP 7AA
1	1/8	1/8	1/8	1/8	3/16	3/16	3/16
2	3/16	3/16	3/16	3/16	3/16	3/16	3/16
3	3/16			3/16	3/16		
4	1/8			1/8	3/16		
DUAL							
Temp Range	DRTP 1	DRTP 1A	DRTP 1AA	DRTP 6	DRTP 7	DRTP 7A	DRTP 7AA
1	3/16	3/16	3/16	3/16			
2	1/4	1/4	1/4	3/16			
3	1/4			1/4			
4	3/16			3/16			

STYLE 78

AVAILABLE OPTIONS and MODIFICATIONS

OPTIONAL ELEMENTS		
RTDs are standardly platinum, 100-ohm, DIN-curve elements with a 0.00385 alpha.		
Option Code	Accuracy (at 0°C)	Construction
RTP1 (std.)	±0.12%	3-wire
RTP1A	±0.06%	3-wire
RTP1AA	±0.01%	3-wire
RTP6	±0.12%	2-wire
RTP7	±0.12%	4-wire
RTP7A	±0.06%	4-wire
RTP7AA	±0.01%	4-wire
Notes:		
1. For dual element, add prefix "D" (e.g., DRTP6)		
2. Additional materials, curves and resistance values are available - see Capabilities brochure.		
ASSEMBLY OPTIONS		
Option Code	Description	
TAG1	Stainless steel tag and wire	
PC25	1/4" NPT process connection	
PC75	3/4" NPT process connection	
RB10	Replace terminal block with customer supplied part	
RB11	Supply assembly with no terminal block inside head	
CAL1	Calibration, NIST traceable calibration [specify point(s)]	
CRT1	Certificate of conformance	
TRANSMITTERS – For complete specs, see Transmitters section		
TR11	4-20 mA, 2-wire transmitter, single input, isolated output; specify range and units of measure (e.g., 0-200°C)	
TR12	4-20 mA, 2-wire transmitter, single input, non-isolated output; specify range and units of measure (e.g., 0-200°C) and terminal head with *.	
TR13	HART®/ 4-20 mA, 2-wire transmitter, single input, isolated output; specify range and units of measure (e.g., 0-200°C) and terminal head with *.	
UNION CONNECTOR (converts male connection to female)		
Option Code	Description	
UC20	Plated steel, 1/2" x 1/2" NPT, explosion-proof rating	
Note: adding the union connector reduces the sensor's L length by 1.88" (see view). Adjust L dimension accordingly.		

EXPLOSION-PROOF TERMINAL HEAD OPTIONS		
Option Code	Process Connection	Conduit Connection
Cast aluminum; screw cover with chain; o-ring gasket (Gasket rated to 100°C exposure); ceramic terminal block; FM/CSA approved for Class I Div. 1, Groups B, C and D; Class II Groups E, F and G; internal ground screw.		
HD71	1/2"	3/4"
Stainless steel (same specs as HD71)		
HD74	1/2"	1/2"
HD75	1/2"	3/4"
Epoxy-coated (same specs as HD71)		
HD80	1/2"	1/2"
HD81	1/2"	3/4"

Note: See Accessories section for additional specs.

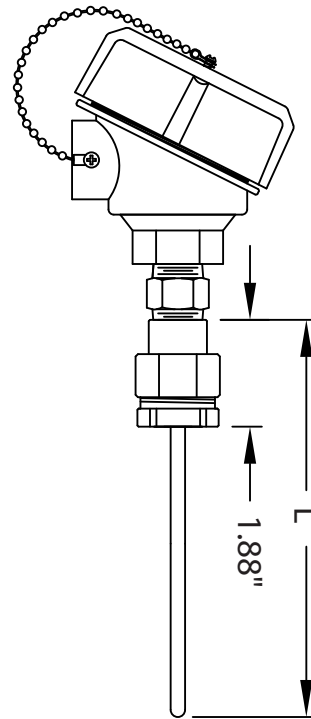

UC20 Option