

**WELD PAD WITH LEADWIRE**

**How to build a part number:**

To order an Applied Sensor Technologies temperature sensor, select the requirements for the categories listed below and fill in the corresponding boxes with your selection. Don't see exactly what you need? Give us a call!

SENSOR TYPE	ASSEMBLY STYLE	SHEATH DIAMETER	SHEATH MATERIAL	TEMPERATURE RANGE	SHEATH LENGTH	LEADWIRE LENGTH	OPTIONS

**SENSOR TYPE** (See page 2-14b for optional elements)

**RTP1** – Platinum; DIN 0.00385; 100 ohm +/- 0.12% @ 0°C; 3-wire construction

**ASSEMBLY STYLE**

**39 – Sheath with flat weld pad and leadwire;** Teflon® insulated conductors; Teflon® jacket; pad same material as sheath, 1" X 1" pad size; 1/8" pad thickness; radiused pad available as an option.

**SHEATH DIAMETER**

**6** – 3/16 (0.188)

**7** – 1/4 (0.250)

**SHEATH MATERIAL**

**3** – stainless steel

**TEMPERATURE RANGE** - Minimum and maximum operating temperatures

**1** – -45 to 260°C (-50 to 500°F)

**2** – -45 to 482°C (-50 to 900°F)

**SHEATH LENGTH** (for lengths greater than L=36", consult AST)

**L#** – (e.g., L6 = 6 inch sheath)

**LEADWIRE LENGTH**

**X#** – (e.g., X72 = 72 inch length)

**OPTIONS** – see page 2-14b

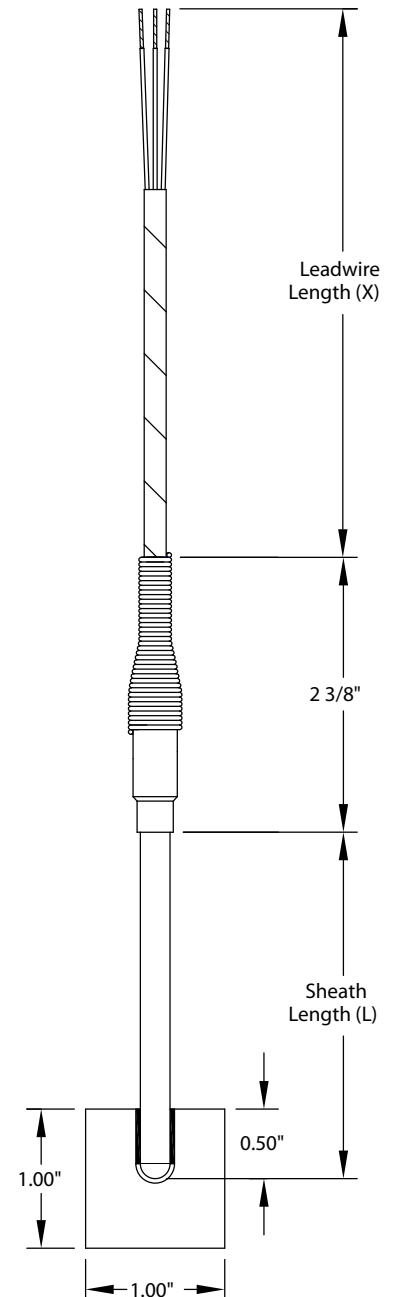

Teflon® is a registered trademark of DuPont

## STYLE 39

### AVAILABLE OPTIONS and MODIFICATIONS

OPTIONAL ELEMENTS		
RTDs are standardly platinum, 100-ohm, DIN-curve elements with a 0.00385 alpha.		
Option Code	Accuracy (at 0°C)	Construction
RTP1 (std.)	±0.12%	3-wire
RTP1A	<b>±0.06%</b>	3-wire
RTP1AA	<b>±0.01%</b>	3-wire
Note: additional materials, curves and resistance values are available - see Capabilities brochure.		
ASSEMBLY OPTIONS		
Option Code	Description	
TAG1	Stainless steel tag and wire	
CAL1	NIST traceable calibration [specify point(s)]	
CRT1	Certificate of conformance	
B45-	45° bend in sheath (specify length from tip in inches e.g., B45-6)	
B90-	90° bend in sheath (specify length from tip in inches e.g., B90-6)	
WIRING CONNECTION OPTIONS		
Option Code	Description	
WC76	#6 spade terminals, plated copper	
WC70	#10 spade terminals, plated copper	
WC84	1/4" push-on insulated terminals, plated copper	
WC90	#10 ring terminals	
WC98	#8 ring terminals	
<b>PLUGS AND JACKS</b> (Note: plug is designed to be attached to sensor assemblies. Jack options – for customer wiring – should only be specified if plug option is also included. Cable clamp is included for both plug and jack options.)		
PJ10	Standard plug, rated to 177°C (350°F)	
PJ20	Standard jack, rated to 177°C (350°F)	

WELD PADS	
Pads are normally supplied flat. For matching a pipe radius, use the codes below:	
WP10	1" nominal pipe size
WP15	1.5" nominal pipe size
WP20	2" nominal pipe size
WP25	2.5" nominal pipe size
WP30	3" nominal pipe size
WP35	3.5" nominal pipe size
WP40	4" nominal pipe size